

Integrated Vacuum Assisted Oil Mist Eliminator "VAE" Series

APPLICATIONS & EQUIPMENT

- ◆ Gas & Steam Turbines
- ◆ Turbo Compressors
- ◆ Generators
- ◆ Gearboxes
- ◆ Rotating Machinery
- ◆ High Speed Couplings
- ◆ Diesel Engines
- ◆ Contact your representative about your specific application.

FEATURES & SPECIFICATIONS

- ◆ Efficiency of 99.97% D.O.P. on 0.3 micron particles
- ◆ Pleated filter element provides increased surface area for low back pressure separation of ultra-fine oil mists
- ◆ Element has a 4000/hr mean life span
- ◆ Blower selected to meet required vacuum levels
- ◆ Corrosion resistant fittings for outdoor use
- ◆ Operating Temp min -20°F (-29°C) max 220°F (104°F)
- ◆ Wide range of operation flows

BENEFITS

Vacuum Assisted Oil Mist Eliminator (VAE) units are the perfect solution for preventing oil leaks through driveshaft seals in crankcases and oil reservoirs along the drive train of large gas and steam turbines, compressors, turbo compressors and reciprocating engines. The VAE runs continuously to provide 3 functions to support your machinery. The main function is to create and maintain a vacuum in the crankcase or reservoir to prevent oil leakage through the driveshaft seals. Secondary functions include the ability to coalesce oil mist while returning oil through a drain line to the reservoir and provide oil free, environmentally friendly emissions.

OPTIONS (Inquires Encouraged)

- ◆ Control Box
- ◆ Support Stand
- ◆ Carbon steel or *Stainless Steel* housings
- ◆ Gauges

CONFIGURATION

Oil Lubrication Skid Application:

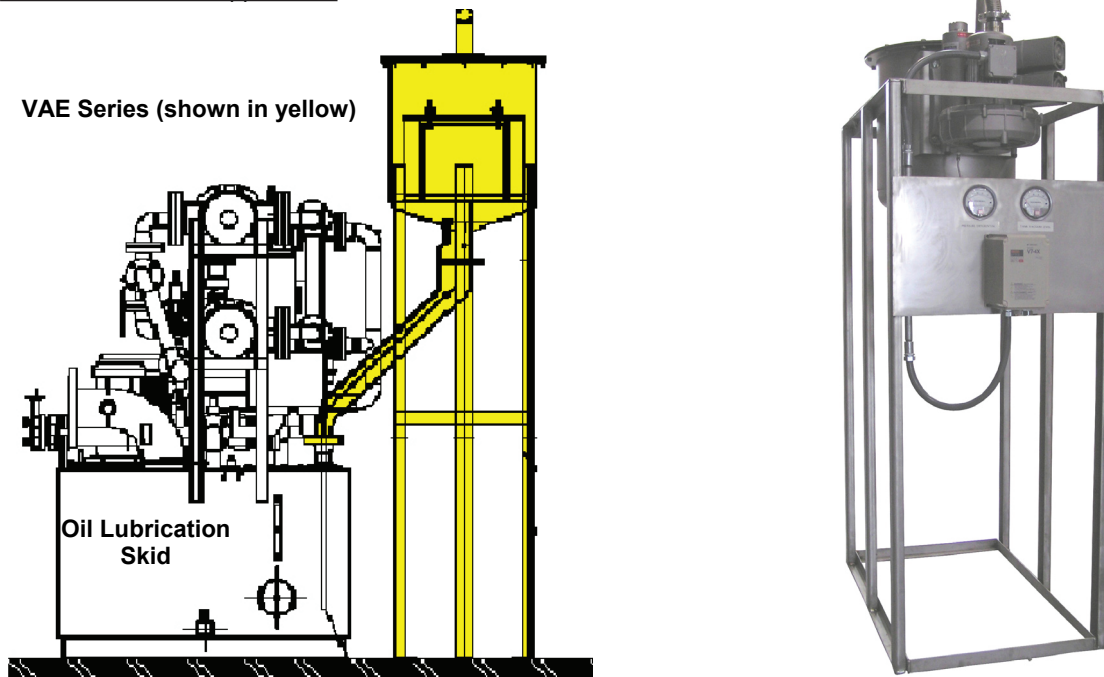

**Note: Blower selection determined by customer specifications.

Integrated Vacuum Assisted Oil Mist Eliminator "VAE" Series

MAJOR SYSTEM COMPONENTS

Regenerative Blower:** Each system requires a different amount of vacuum in its housing to prevent oil leakage through the seals around the drive shafts. The vacuum is created by a regenerative blower. A blower system is sized for each application according to the cubic volume of the housing and leakage rates of the seal.



Coalescing Filter Element: Due to the turbulent oil flow and the temperature inside the oil reservoir, oil mist droplets will be entrained in the air stream created by the blower. This oil needs to be removed before it is exhausted to atmosphere, where it would cause environmental damage. The coalescing element not only removes the oil but collects it in a droplet form and then deposits it in the bottom of the filter housing. The collected oil is drained back to the oil reservoir, reducing oil loss and maintenance to the system.



APPLICATION PHOTOS



**Note: Blower selection determined by customer specifications.

